

Xploded view Model: CBS12Q

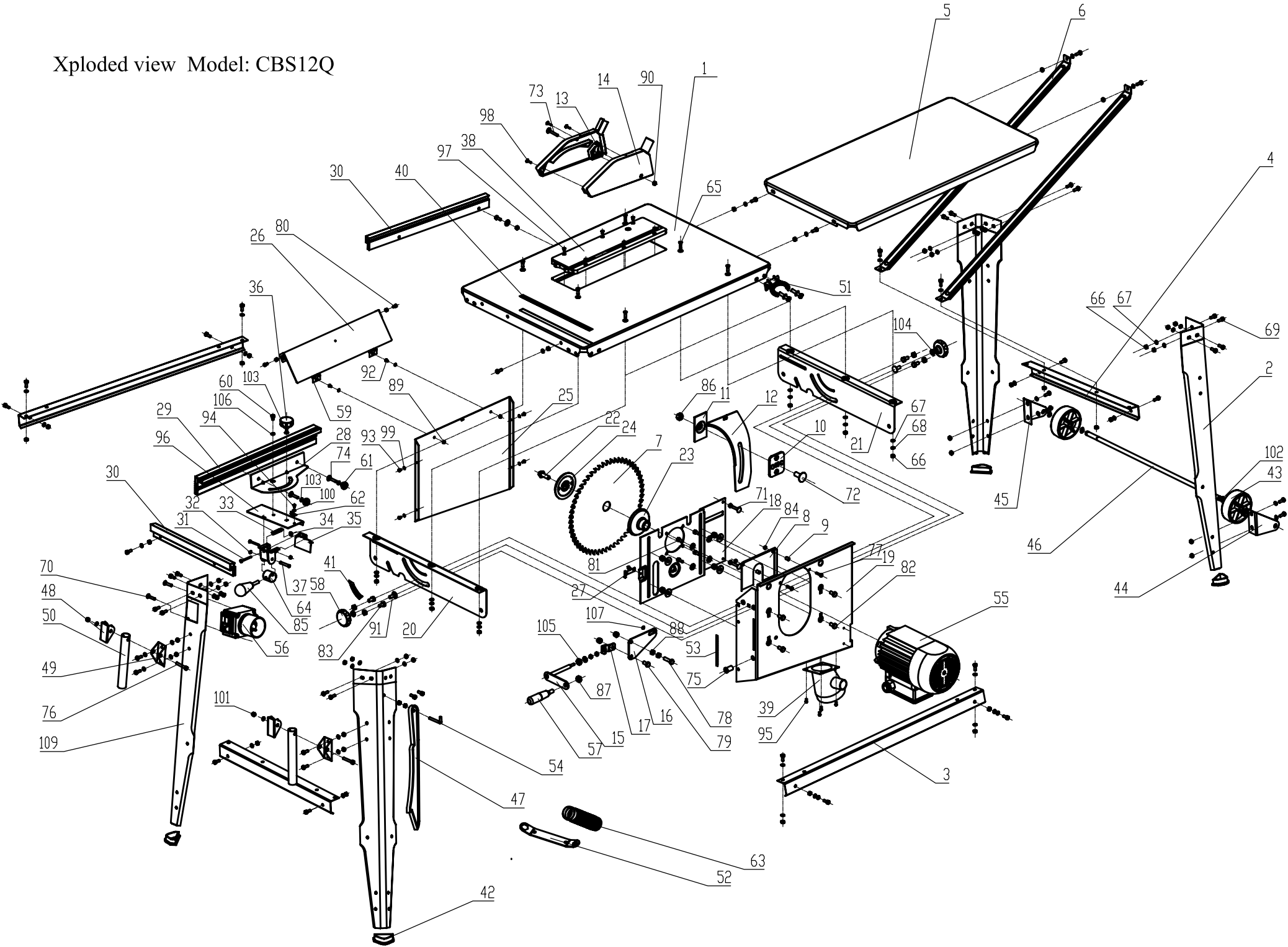

Part No.	Description	Q'ty	Part No.	Description	Q'ty
1	Working table	1	56	Switch	1
2	Stand leg	3	57	Blade height setting handle	1
3	Strut long	2	58	Locking knob	2
4	Strut short	2	59	Hinge	2
5	Extension table	1	60	Fit bolt	1
6	Strut-extension table	2	61	Nut	2
7	Saw blade	1	62	Scale point	1
8	Holding plate	1	63	Dust Extractor	1
9	Holding plate tube	2	64	Eccentric wheel	1
10	Riving knife sliding seat	1	65	Hexagon socket countersunk(flat) head cap screw	6
11	Pressure plate	1	66	Hexagon nut 1-style	42
12	Riving knife	1	67	Plain washer	58
13	Blade cover right (w/ side plate)	1	68	Spring washer	10
14	Blade cover left (w/ side plate)	1	69	Hexagon bolt	45
15	Handle	1	70	Cross recessed pan head tapping screw	4
16	Guide Block	1	71	Cup head square neck bolt	2
17	Connecting block	1	72	Cup head square neck bolt	1
18	Motor Bracket	1	73	Cross recessed pan head screw	1
19	Chips box	1	74	Cup head square neck bolt	2
20	Supporting plate,front	1	75	Hex. Rivet nut	1
21	Supporting plate,rear	1	76	Hexagon head bolt	2
22	Blade bolt	1	77	Hexagon head bolt	2
23	Saw blade flange	1	78	Hexagon head bolt	1
24	Saw blade plate	1	79	Hexagon head bolt	1
25	Clip case	1	80	Hexagon head bolt	45
26	Clip case protective cap	1	81	Hexagon head bolt	4
27	Point	1	82	Hexagon head bolt	4
28	Mitre gauge	1	83	Hexagon head bolt	4
29	Rip fence extrusion	1	84	Hexagon nut 1-style	2
30	Rip Fence carrier	2	85	Locking handle	1
31	Cross recessed pan head screw	2	86	Hexagon nut 1-style	1
32	Circlips for shaft	1	87	Hexagon nut 1-style	1
33	Spring	1	88	Hexagon nut 1-style	2
34	Plain washer	6	89	Hex. Locking nut 1-style	3
35	Locking board	1	90	Hex. Locking nut 1-style	4
36	Mitre gauge locking knob		91	Cup square neck bolt w/ short neck	2
37	Pin		92	Cross recessed pan head screw	2
38	Table insert	1	93	Cross recessed pan head screw	11
39	Dust Extractor	1	94	Cross recessed pan head screw	5
40	Table scale	1	95	Cross recessed pan head screw	11
41	Angle Label	1	96	Miter gauge supporting plate	1
42	Rubber Foot	4	97	Cross recessed countersunk(flat) head screw	4
43	Wheel	2	98	Cross recessed countersunk(flat) head tapping screw	5
44	Wheel frame,left	1	99	Lock washer external teeth	7
45	Wheel frame,right	1	100	Lock washer external teeth	1
46	Wheel axis	1	101	Hex. Locking nut 1-style	12
47	Wooden push handle	1	102	Circlips for shaft	1
48	Pushing handle cover	2	103	Large plain washer	9
49	Pushing handle seat	2	104	Large plain washer	4
50	Pushing handle	2	105	Hex. Locking nut 1-style	1
51	Hose support	1	106	Tensile spring	1
52	Wrench	1	107	Circlips for shaft	1
53	Height scale	1	108	Hex. Nut	2
54	Hook	1	109	Stand leg	1
55	Motor	1			